

# X20(c)PS3300

## 1 General information

The supply module is equipped with a feed for the X2X Link as well as the internal I/O supply.

- Feed for X2X Link and internal I/O supply
- Electrical isolation of feed and X2X Link supply
- Redundancy of X2X Link supply possible by operating multiple supply modules simultaneously

## 2 Coated modules

Coated modules are X20 modules with a protective coating for the electronics component. This coating protects X20c modules from condensation and corrosive gases.

The modules' electronics are fully compatible with the corresponding X20 modules.

**For simplification purposes, only images and module IDs of uncoated modules are used in this data sheet.**

The coating has been certified according to the following standards:

- Condensation: BMW GS 95011-4, 2x 1 cycle
- Corrosive gas: EN 60068-2-60, Method 4, Exposure 21 days



## 3 Order data

Model number	Short description	Figure
	<b>Power supplies</b>	
X20PS3300	X20 power supply module, for X2X Link and internal I/O supply	
X20cPS3300	X20 power supply module, coated, for X2X Link and internal I/O supply	
	<b>Required accessories</b>	
	<b>Bus modules</b>	
X20BM01	X20 power supply bus module, 24 VDC keyed, internal I/O supply interrupted to the left	
X20BM05	X20 power supply bus module, with node number switch, 24 VDC keyed, internal I/O supply interrupted to the left	
X20cBM01	X20 power supply bus module, coated, 24 VDC keyed, internal I/O supply interrupted to the left	
	<b>Terminal blocks</b>	
X20TB12	X20 terminal block, 12-pin, 24 VDC keyed	

Table 1: X20PS3300, X20cPS3300 - Order data

## 4 Technical data

Product ID	X20PS3300	X20cPS3300
<b>Short description</b>		
Power supply module	24 VDC supply module for I/O and bus	
<b>General information</b>		
B&R ID code	0x1BC0	0xDF13
Status indicators	Overload, operating state, module status	
Diagnostics		
Module run/error	Yes, using status LED and software	
Overload	Yes, using status LED and software	
Power consumption <sup>1)</sup>		
Bus	1.31 W	
Internal I/O	0.6 W	
Additional power dissipation caused by the actuators (resistive) [W]	-	
Electrical isolation		
I/O feed - I/O supply	No	
X2X Link feed - X2X Link supply	Yes	
Certification		
CE	Yes	
cULus	Yes	
cCSAus HazLoc Class 1 Division 2	Yes	-
ATEX Zone 2 <sup>2)</sup>		Yes
KC	Yes	-
GL		Yes
LR		Yes
GOST-R		Yes
<b>X2X Link input supply</b>		
Input voltage	24 VDC -15% / +20%	
Input current	Max. 0.7 A	
Fuse	Integrated, cannot be replaced	
Reverse polarity protection	Yes	
<b>X2X Link supply output</b>		
Nominal output power	7 W	
Parallel operation	Yes <sup>3)</sup>	
Redundant operation	Yes	
Overload behavior	Short circuit / temporary overload protection	
<b>Input I/O supply</b>		
Input voltage	24 VDC -15% / +20%	
Fuse	Required line fuse: Max. 10 A, slow-blow	
Reverse polarity protection	No	
<b>Output I/O supply</b>		
Rated output voltage	24 VDC	
Behavior if a short circuit occurs	Required line fuse	
Permitted contact load	10 A	
<b>Operating conditions</b>		
Mounting orientation		
Horizontal	Yes	
Vertical	Yes	
Installation at elevations above sea level		
0 to 2000 m	No limitations	
>2000 m	Reduction of ambient temperature by 0.5°C per 100 m	
EN 60529 protection	IP20	
<b>Environmental conditions</b>		
Temperature		
Operation		
Horizontal installation	-25 to 60°C	
Vertical installation	-25 to 50°C	
Derating	See section "Derating"	
Storage	-40 to 85°C	
Transport	-40 to 85°C	

Table 2: X20PS3300, X20cPS3300 - Technical data

Product ID	X20PS3300	X20cPS3300
Relative humidity		
Operation	5 to 95%, non-condensing	Up to 100%, condensing
Storage	5 to 95%, non-condensing	
Transport	5 to 95%, non-condensing	
<b>Mechanical characteristics</b>		
Note	Order 1x X20TB12 terminal block separately Order 1x X20BM01 supply bus module separately	Order 1x X20TB12 terminal block separately Order 1x X20cBM01 supply bus module separately
Spacing	12.5 <sup>+0.2</sup> mm	

Table 2: X20PS3300, X20cPS3300 - Technical data

- The values specified here are maximum values. The exact calculation is also available for download as a data sheet with the other module documentation on the B&R website.
- Ta min.: 0°C  
Ta max.: See environmental conditions
- In parallel operation, only 75% of the rated power can be assumed. It is important to make sure that all power supplies operating in parallel are switched on and off at the same time.

## 5 LED status indicators

For a description of the various operating modes, see the section "re LEDs" in chapter 2 "System characteristics" of the X20 system user's manual.

Figure	LED	Color	Status	Description
	r	Green	Off	No power to module
			Single flash	RESET mode
			Blinking	PREOPERATIONAL mode
			On	RUN mode
	e	Red	Off	No power to module or everything OK
			Double flash	LED indicates one of the following states: <ul style="list-style-type: none"> <li>The X2X Link supply for the power supply is overloaded</li> <li>I/O supply too low</li> <li>Input voltage for X2X Link supply too low</li> </ul>
	e + r		Red on / Green single flash	Invalid firmware
l	Red	Off	The X2X Link supply is within the valid limits	
		On	The X2X Link supply for the power supply is overloaded	

## 6 Pinout

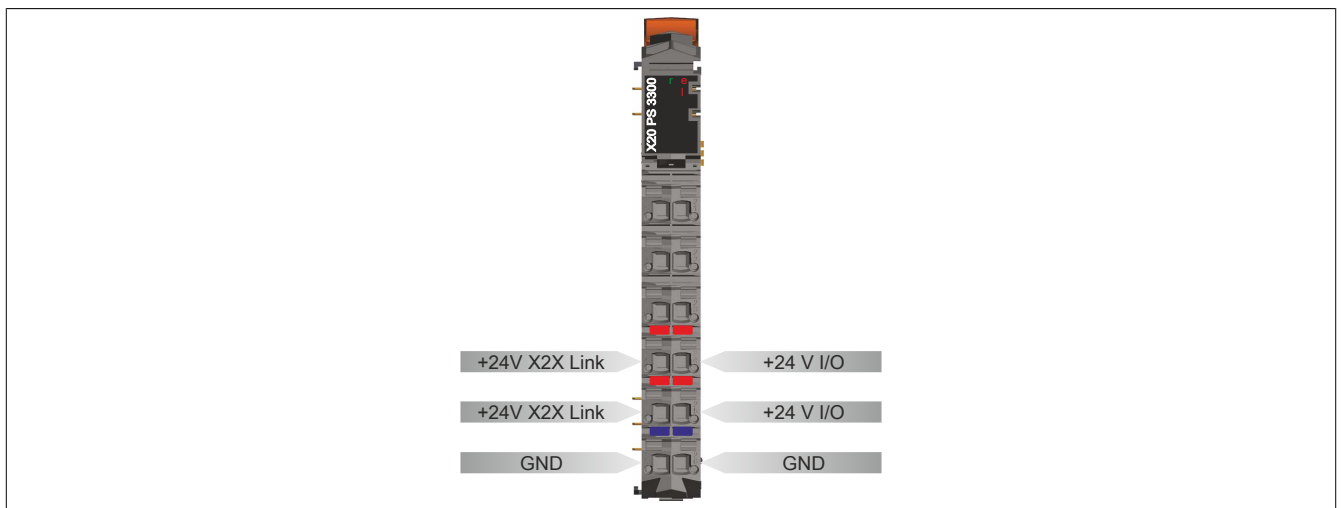

## 7 Connection examples

### With 2 separate supplies

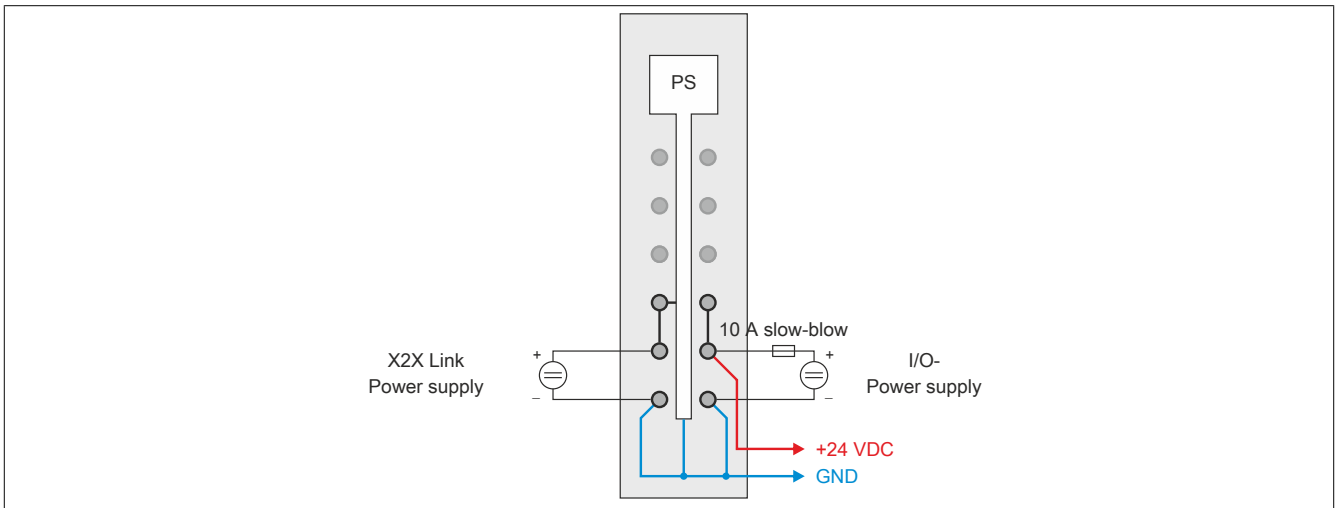

### With a supply and jumper

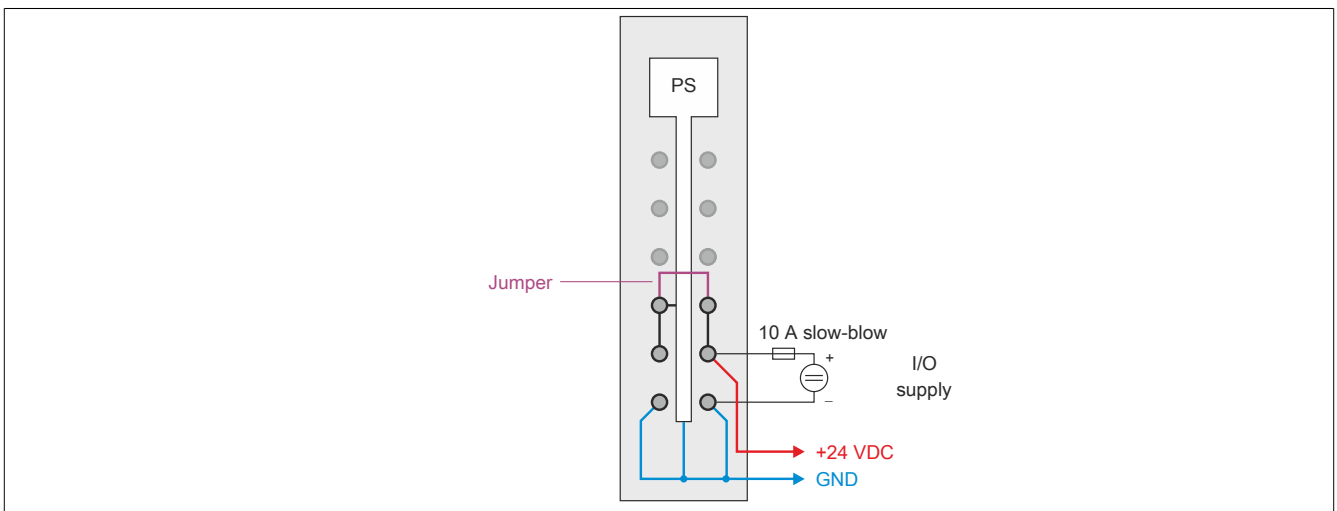

## 8 Derating

The rated output current for the supply is 7 W. Derating must be taken into consideration based on mounting orientation.

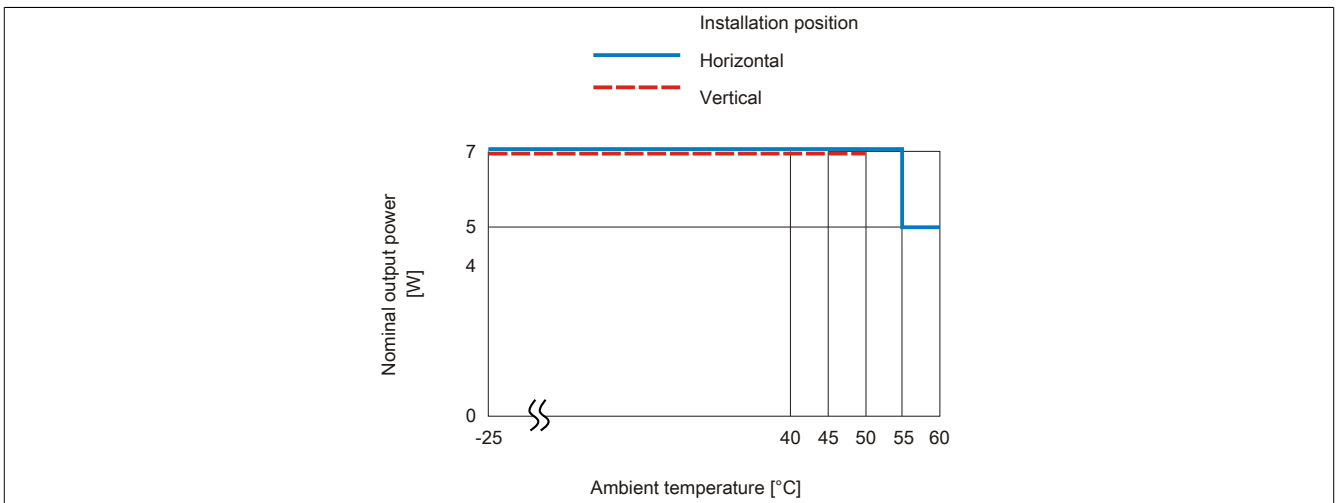

## 9 Register description

### 9.1 General data points

In addition to the registers listed in the register description, the module also has other more general data points. These registers are not specific to the module but contain general information such as serial number and hardware version.

These general data points are listed in the "General data points" section of chapter 4 "X20 system modules" in the X20 system user's manual.

### 9.2 Function model 0 - Standard

Register	Name	Data type	Read		Write	
			Cyclic	Non-cyclic	Cyclic	Non-cyclic
0	Module status	USINT	•			
	StatusInput01	Bit 0				
	StatusInput02	Bit 2				
2	SupplyCurrent	USINT	•			
4	SupplyVoltage	USINT	•			

### 9.3 Function model 254 - Bus controller

The module occupies 1 logical analog slot on CAN I/O.

Register	Offset <sup>1)</sup>	Name	Data type	Read		Write	
				Cyclic	Non-cyclic	Cyclic	Non-cyclic
0	0	Module status	UINT	•			
		StatusInput01	Bit 0				
		StatusInput02	Bit 2				
2	2	SupplyCurrent	UINT	•			
4	4	SupplyVoltage	UINT	•			

1) The offset specifies the position of the register within the CAN object.

### 9.4 Module status

Name:

Module status

The following voltage and current states of the module are monitored in this register:

Bus supply current:	A bus supply current of >2.3A is displayed as a warning.
Bus supply voltage:	A bus supply voltage of <4.7V is displayed as a warning.
24 VDC I/O supply voltage:	An I/O supply voltage of <20.4 V is displayed as a warning.

Function model	Data type	Value
0 - Standard	USINT	See bit structure.
254 - Bus controller	UINT	See bit structure.

Bit structure:

Bit	Name	Value	Information
0	StatusInput01	0	No error
		1	Warning - overcurrent (>2.3 A) or undervoltage (<4.7 V)
1	Reserved	0	
2	StatusInput02	0	I/O supply above the warning level of 20.4 V
		1	I/O supply below the warning level of 20.4 V
3 - x	Reserved	0	

## 9.5 Bus supply current

Name:  
SupplyCurrent

This register displays the bus supply current measured at a resolution of 0.1 A.

Function model	Data type
0 - Standard	USINT
254 - Bus controller	UINT

## 9.6 Bus supply voltage

Name:  
SupplyVoltage

This register displays the bus supply voltage measured at a resolution of 0.1 V.

Function model	Data type
0 - Standard	USINT
254 - Bus controller	UINT

## 9.7 Minimum cycle time

The minimum cycle time defines how far the bus cycle can be reduced without communication errors occurring. It should be noted that very fast cycles decrease the idle time available for handling monitoring, diagnostics and acyclic commands.

Minimum cycle time
100 $\mu$ s

## 9.8 Minimum I/O update time

The minimum I/O update time defines how far the bus cycle can be reduced while still allowing an I/O update to take place in each cycle.

Minimum I/O update time
2 ms