

X20AI2622

1 General information

The module is equipped with 2 inputs with 13-bit (including sign) digital converter resolution. It is possible to select between the current and voltage signal using different terminals.

This module is designed for X20 6-pin terminal blocks. If needed (e.g. for logistical reasons), the 12-pin terminal block can also be used.

- 2 analog inputs
- Either current or voltage signal possible
- 13-bit digital converter resolution

2 Order data

Model number	Short description	Figure
	Analog inputs	
X20AI2622	X20 analog input module, 2 inputs, ± 10 V or 0 to 20 mA / 4 to 20 mA, 13-bit converter resolution, configurable input filter	
	Required accessories	
	Bus modules	
X20BM11	X20 bus module, 24 VDC keyed, internal I/O supply continuous	
X20BM15	X20 bus module, with node number switch, 24 VDC keyed, internal I/O supply continuous	
	Terminal blocks	
X20TB06	X20 terminal block, 6-pin, 24 VDC keyed	
X20TB12	X20 terminal block, 12-pin, 24 VDC keyed	

Table 1: X20AI2622 - Order data

3 Technical data

Model number	X20AI2622
Short description	
I/O module	2 analog inputs ± 10 V or 0 to 20 mA / 4 to 20 mA
General information	
B&R ID code	0x1B9E
Status indicators	I/O function per channel, operating state, module status
Diagnostics	
Module run/error	Yes, using status LED and software
Inputs	Yes, using status LED and software
Channel type	Yes, using software
Power consumption	
Bus	0.01 W
Internal I/O	0.8 W ¹⁾
Additional power dissipation caused by actuators (resistive) [W]	-
Certifications	
CE	Yes
KC	Yes
EAC	Yes
UL	cULus E115267 Industrial control equipment
HazLoc	cCSAus 244665 Process control equipment for hazardous locations Class I, Division 2, Groups ABCD, T5
ATEX	Zone 2, II 3G Ex nA nC IIA T5 Gc IP20, Ta (see X20 user's manual) FTZU 09 ATEX 0083X
DNV GL	Temperature: B (0 - 55°C) Humidity: B (up to 100%) Vibration: B (4 g) EMC: B (bridge and open deck)
LR	ENV1
Analog inputs	
Input	± 10 V or 0 to 20 mA / 4 to 20 mA, via different terminal connections
Input type	Differential input
Digital converter resolution	
Voltage	± 12 -bit
Current	12-bit
Conversion time	300 μ s for all inputs
Output format	
Data type	INT
Voltage	INT 0x8001 - 0x7FFF / 1 LSB = 0x0008 = 2.441 mV
Current	INT 0x0000 - 0x7FFF / 1 LSB = 0x0008 = 4.883 μ A
Input impedance in signal range	
Voltage	20 M Ω
Current	-
Load	
Voltage	-
Current	<400 Ω
Input protection	Protection against wiring with supply voltage
Permissible input signal	
Voltage	Max. ± 30 V
Current	Max. ± 50 mA
Output of digital value during overload	Configurable
Conversion procedure	SAR
Input filter	3rd-order low pass / cutoff frequency 1 kHz
Max. error at 25°C	
Voltage	
Gain	0.08% ²⁾
Offset	0.015% ³⁾
Current	
Gain	0 to 20 mA = 0.08 % / 4 to 20 mA = 0.1 % ²⁾
Offset	0 to 20 mA = 0.03 % / 4 to 20 mA = 0.16 % ⁴⁾
Max. gain drift	
Voltage	0.006 %/°C ²⁾
Current	0 to 20 mA = 0.009 %/°C 4 to 20 mA = 0.0113 %/°C ²⁾
Max. offset drift	
Voltage	0.002 %/°C ³⁾
Current	0 to 20 mA = 0.004 %/°C 4 to 20 mA = 0.005 %/°C ⁴⁾

Table 2: X20AI2622 - Technical data

Model number	X20AI2622
Common-mode rejection	
DC	70 dB
50 Hz	70 dB
Common-mode range	±12 V
Crosstalk between channels	<-70 dB
Nonlinearity	
Voltage	<0.025% ³⁾
Current	<0.05% ⁴⁾
Isolation voltage between channel and bus	500 V _{eff}
Electrical properties	
Electrical isolation	Channel isolated from bus Channel not isolated from channel
Operating conditions	
Mounting orientation	
Horizontal	Yes
Vertical	Yes
Installation elevation above sea level	
0 to 2000 m	No limitations
>2000 m	Reduction of ambient temperature by 0.5°C per 100 m
Degree of protection per EN 60529	IP20
Ambient conditions	
Temperature	
Operation	
Horizontal mounting orientation	-25 to 60°C
Vertical mounting orientation	-25 to 50°C
Derating	-
Storage	-40 to 85°C
Transport	-40 to 85°C
Relative humidity	
Operation	5 to 95%, non-condensing
Storage	5 to 95%, non-condensing
Transport	5 to 95%, non-condensing
Mechanical properties	
Note	Order 1x X20TB06 or X20TB12 terminal block separately Order 1x X20BM11 bus module separately
Spacing	12.5 ^{+0.2} mm

Table 2: X20AI2622 - Technical data

- 1) To reduce power dissipation, B&R recommends bridging unused inputs on the terminals or configuring them as current signals.
- 2) Based on the current measured value.
- 3) Based on the 20 V measurement range.
- 4) Based on the 20 mA measurement range.

4 LED status indicators

For a description of the various operating modes, see section "Additional information - Diagnostic LEDs" of the X20 system user's manual.

Figure	LED	Color	Status	Description
	r	Green	Off	No power to module
			Single flash	RESET mode
			Blinking	PREOPERATIONAL mode
			On	RUN mode
	e	Red	Off	No power to module or everything OK
			On	Error or reset status
	e + r		Red on / Green single flash	Invalid firmware
	1 - 2	Green	Off	Open line ¹⁾ or sensor is disconnected
			Blinking	Input signal overflow or underflow
			On	Analog/digital converter running, value OK

- 1) Open line detection only possible when measuring voltage.

5 Pinout

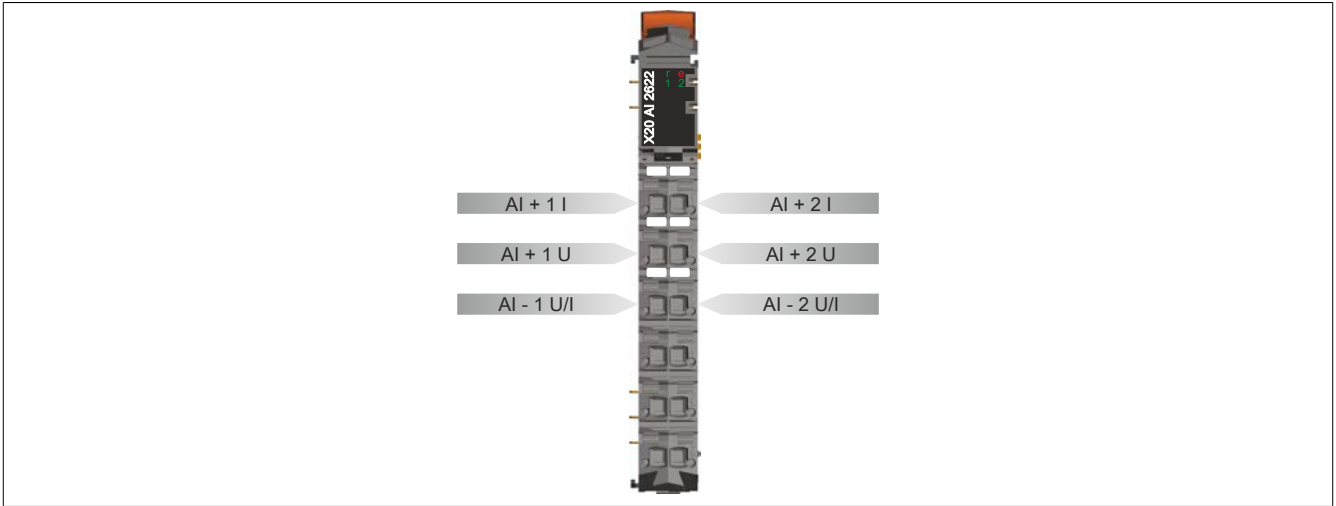

6 Connection example

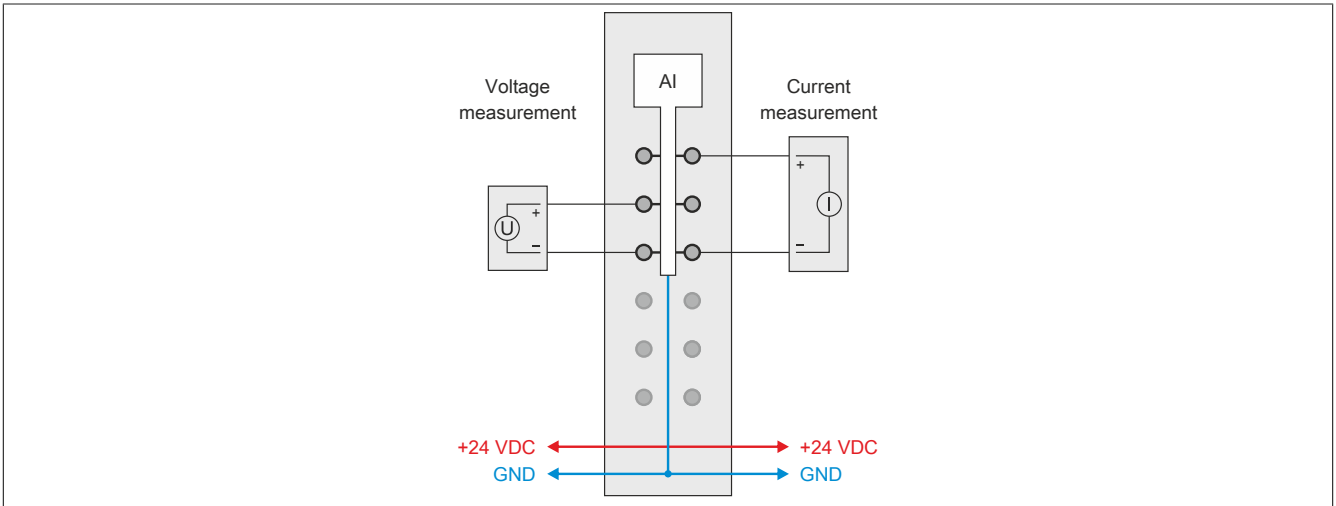

7 Input circuit diagram

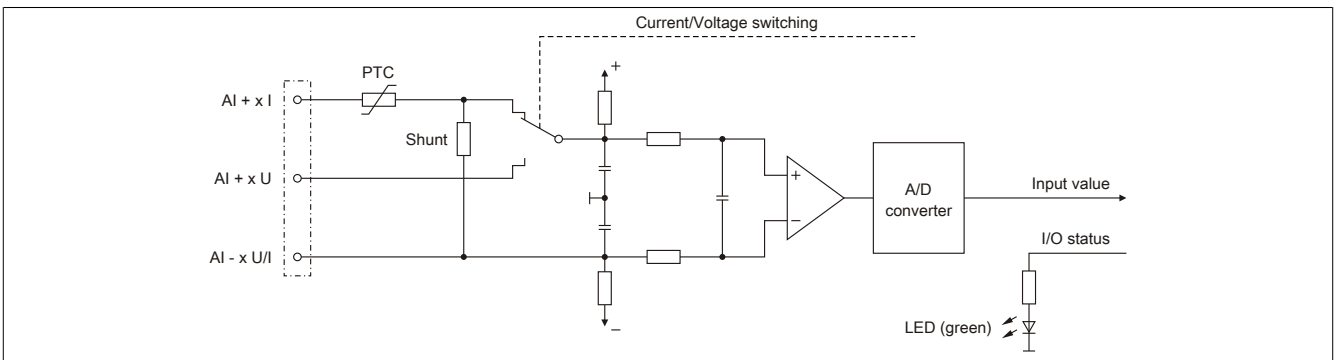

8 Register description

8.1 General data points

In addition to the registers described in the register description, the module has additional general data points. These are not module-specific but contain general information such as serial number and hardware variant.

General data points are described in section "Additional information - General data points" of the X20 system user's manual.

8.2 Function model 0 - Standard

Register	Name	Data type	Read		Write	
			Cyclic	Acyclic	Cyclic	Acyclic
Configuration						
16	ConfigOutput01 (Input filter)	USINT				•
18	ConfigOutput02 (Channel type)	USINT				•
20	ConfigOutput03 (Lower value)	INT				•
22	ConfigOutput04 (Upper limit value)	INT				•
Communication						
0	AnalogInput01	INT	•			
2	AnalogInput02	INT	•			
30	StatusInput01	USINT	•			

8.3 Function model 254 - Bus controller

Register	Offset ¹⁾	Name	Data type	Read		Write	
				Cyclic	Acyclic	Cyclic	Acyclic
Configuration							
16	-	ConfigOutput01 (Input filter)	USINT				•
18	-	ConfigOutput02 (Channel type)	USINT				•
20	-	ConfigOutput03 (Lower limit value)	INT				•
22	-	ConfigOutput04 (Upper limit value)	INT				•
Communication							
0	0	AnalogInput01	INT	•			
2	2	AnalogInput02	INT	•			
30	-	StatusInput01	USINT		•		

1) The offset specifies the position of the register within the CAN object.

8.3.1 Using the module on the bus controller

Function model 254 "Bus controller" is used by default only by non-configurable bus controllers. All other bus controllers can use additional registers and functions depending on the fieldbus used.

For detailed information, see section "Additional information - Using I/O modules on the bus controller" of the X20 user's manual (version 3.50 or later).

8.3.2 CAN I/O bus controller

The module occupies 1 analog logical slot on CAN I/O.

8.4 Analog inputs

The input state is collected with a fixed offset to the network cycle and transferred in the same cycle.

8.5 Analog input values

Name:

AnalogInput01 to AnalogInput02

The analog input value are mapped to this register depending on the configured operating mode.

Data type	Value	Input signal:
INT	-32768 to 32767	Voltage signal -10 to 10 VDC
	0 to 32767	Current signal 0 to 20 mA
	-8192 to 32767	Current signal 4 to 20 mA (value 0 corresponds to 4 mA)

8.6 Input filter

This module is equipped with a configurable input filter. The minimum X2X cycle time must be $>500 \mu\text{s}$. Filtering is disabled for shorter X2X cycle times.

If the input filter is active, then the channels are scanned in 1 ms cycles. The time offset between the channels is 200 μs . Conversion is performed acyclically to the X2X cycle.

Information:

The filter sampling time is fixed at 1 ms and is acyclic to the X2X cycle.

8.6.1 Input ramp limiting

Input ramp limiting can only be performed in conjunction with filtering. Input ramp limiting is performed before filtering.

The difference of the input value change is checked for exceeding the specified limit. In the event of overshoot, the tracked input value is equal to the old value \pm the limit value.

Adjustable limit values:

Value	Limit value
0	The input value is used without limitation.
1	0x3FFF = 16383
2	0x1FFF = 8191
3	0x0FFF = 4095
4	0x07FF = 2047
5	0x03FF = 1023
6	0x01FF = 511
7	0x00FF = 255

Input ramp limiting is well suited for suppressing disturbances (spikes). The following examples show the functionality of input ramp limiting based on an input jump and a disturbance.

Example 1

The input value jumps from 8000 to 17000. The diagram shows the tracked input value with the following settings:

Input ramp limiting = 4 = 0x07FF = 2047

Filter level = 2

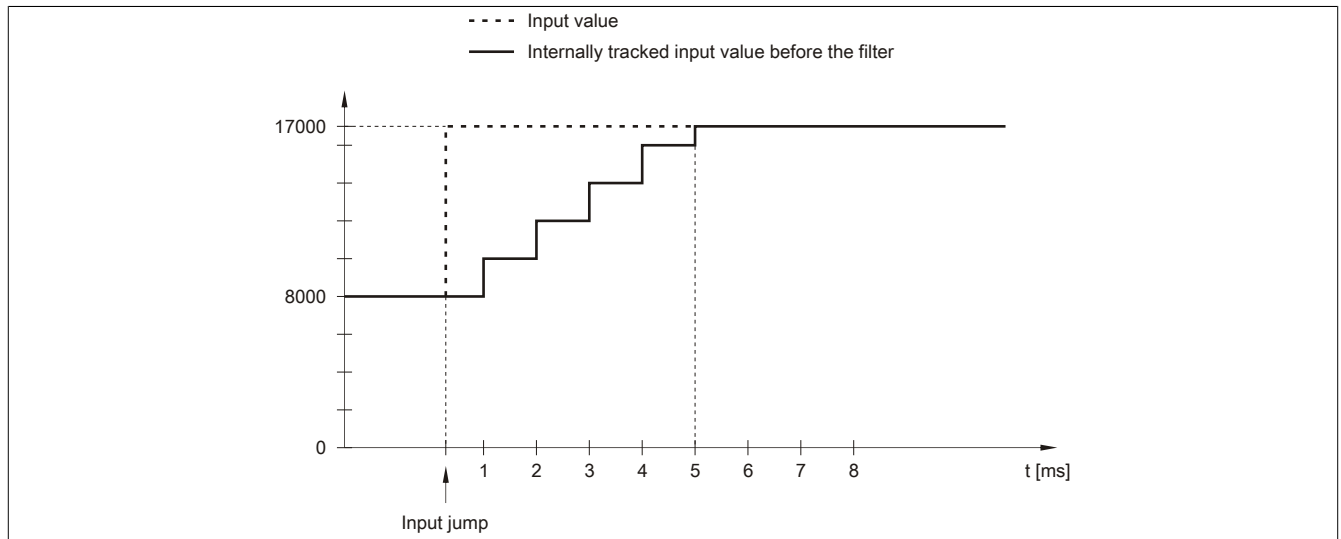

Figure 1: Tracked input value for input jump

Example 2

A disturbance interferes with the input value. The diagram shows the tracked input value with the following settings:

Input ramp limiting = 4 = 0x07FF = 2047

Filter level = 2

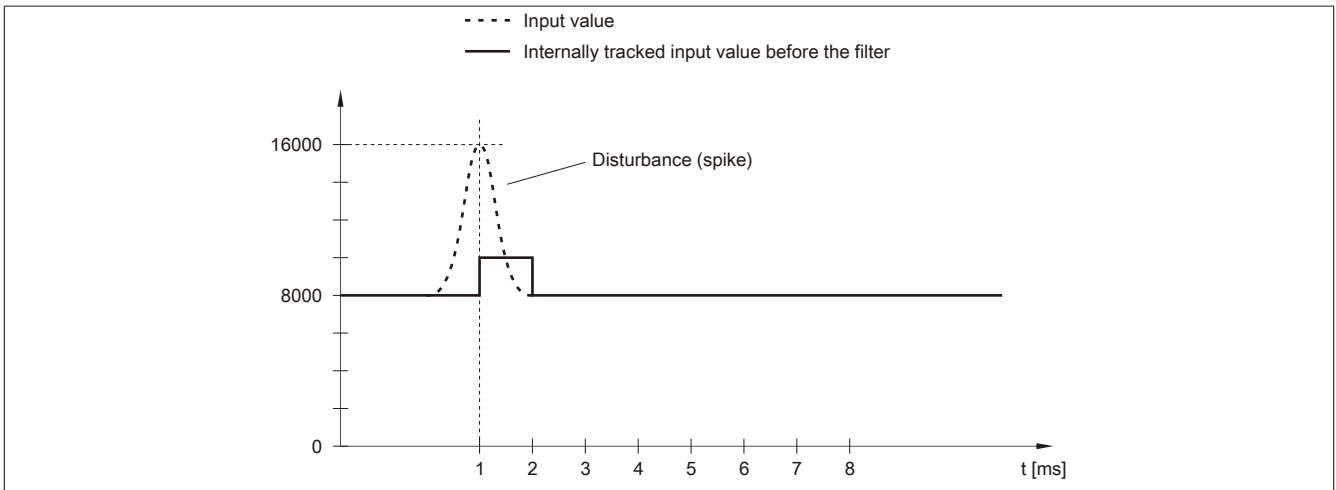

Figure 2: Adjusted input value for disturbance

8.6.2 Filter level

A filter can be defined to prevent large input jumps. This filter is used to bring the input value closer to the actual analog value over a period of several milliseconds.

Filtering takes place after input ramp limitation.

Formula for calculating the input value:

$$\text{Value}_{\text{New}} = \text{Value}_{\text{Old}} - \frac{\text{Value}_{\text{Old}}}{\text{Filter level}} + \frac{\text{Input value}}{\text{Filter level}}$$

Adjustable filter levels:

Value	Filter level
0	Filter switched off
1	Filter level 2
2	Filter level 4
3	Filter level 8
4	Filter level 16
5	Filter level 32
6	Filter level 64
7	Filter level 128

The following examples show how filtering works in the event of an input jump or disturbance.

Example 1

The input value jumps from 8000 to 16000. The diagram shows the calculated value with the following settings:

Input ramp limiting = 0

Filter level = 2 or 4

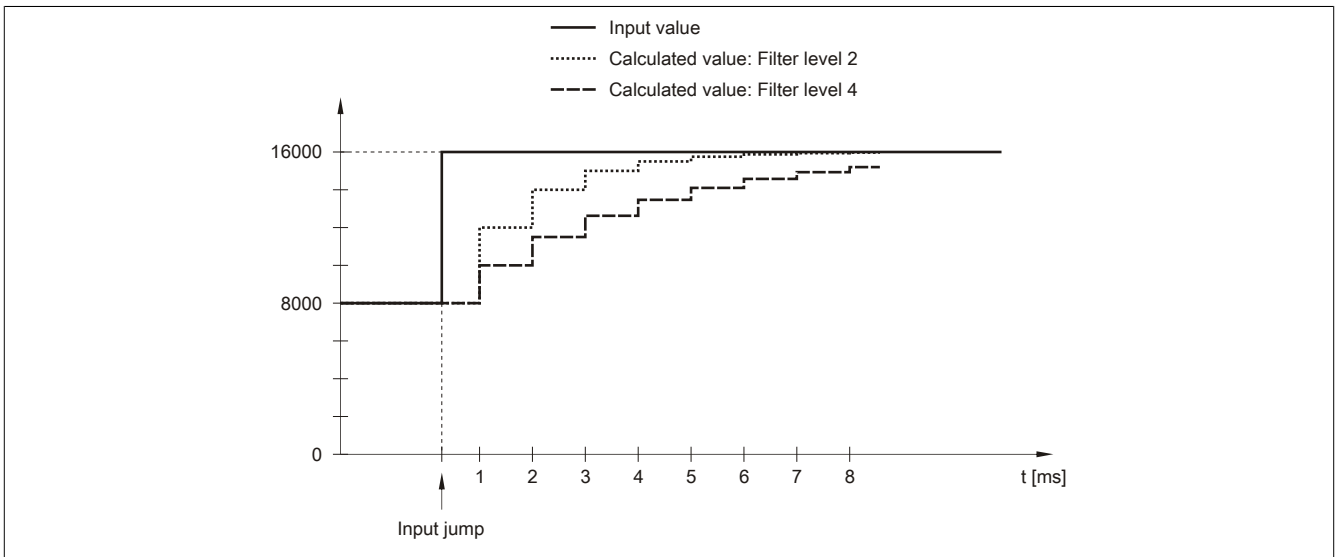

Figure 3: Calculated value during input jump

Example 2

A disturbance interferes with the input value. The diagram shows the calculated value with the following settings:

Input ramp limiting = 0

Filter level = 2 or 4

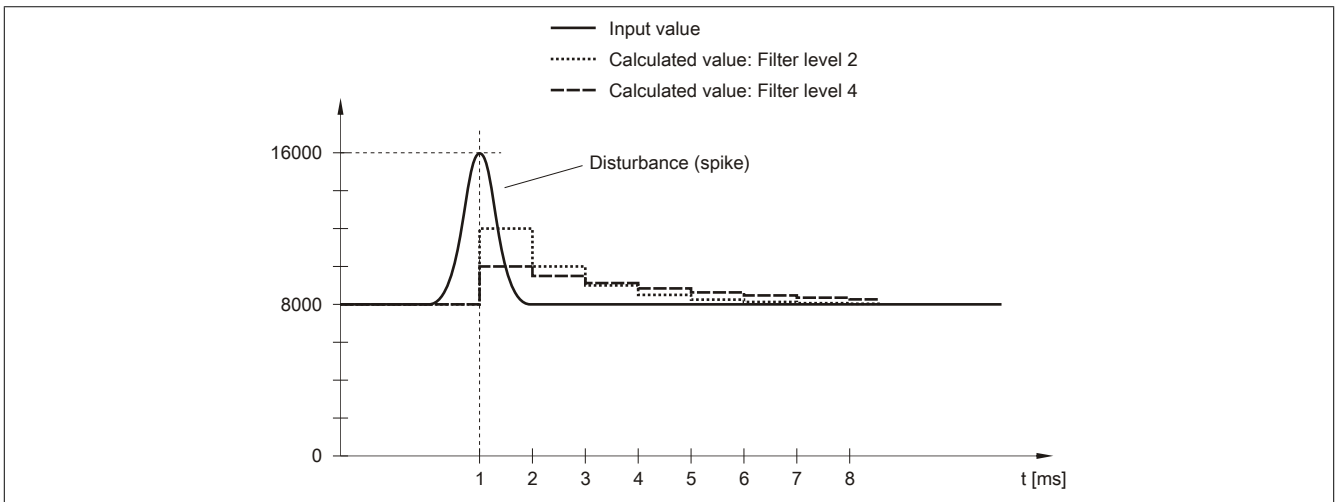

Figure 4: Calculated value during disturbance

8.7 Configuring the input filter

Name:

ConfigOutput01

This register is used to define the filter level and input ramp limitation of the input filter.

Data type	Values	Bus controller default setting
USINT	See bit structure.	0

Bit structure:

Bit	Description	Value	Information
0 - 2	Defines the filter level	000	Filter disabled (bus controller default setting)
		001	Filter level 2
		010	Filter level 4
		011	Filter level 8
		100	Filter level 16
		101	Filter level 32
		110	Filter level 64
		111	Filter level 128
3	Reserved	0	
4 - 6	Defines the input ramp limit	000	The input value is applied without limitation (bus controller default setting)
		001	Limit value = 0x3FFF (16383)
		010	Limit value = 0x1FFF (8191)
		011	Limit value = 0x0FFF (4095)
		100	Limit value = 0x07FF (2047)
		101	Limit value = 0x03FF (1023)
		110	Limit value = 0x01FF (511)
		111	Limit value = 0x00FF (255)
7	Reserved	0	

8.8 Channel type

Name:

ConfigOutput02

This register can be used to define the type and range of signal measurement.

Each channel is capable of handling either current or voltage signals. This differentiation is made using different terminals and an integrated switch in the module. The switch is automatically activated by the module depending on the specified configuration. The following input signals can be set:

- ± 10 V voltage signal (default)
- 0 to 20 mA current signal
- 4 to 20 mA current signal

Data type	Values	Bus controller default setting
USINT	See the bit structure.	0

Bit structure:

Bit	Description	Value	Information
0	Channel 1	0	Voltage signal (bus controller default setting)
		1	Current signal, measurement range corresponding to bit 4
1	Channel 2	0	Voltage signal
		1	Current signal, measurement range corresponding to bit 5
2 - 3	Reserved	0	
4	Channel 1: Current measurement range	0	0 to 20 mA current signal
		1	4 to 20 mA current signal
5	Channel 2: Current measurement range	0	0 to 20 mA current signal
		1	4 to 20 mA current signal
6 - 7	Reserved	0	

8.9 Limit values

The input signal is monitored at the upper and lower limit values. These must be defined according to the operating mode:

Limit value (default)	Voltage signal ± 10 V		Current signal 0 to 20 mA		Current signal 4 to 20 mA	
Upper maximum limit value	+10 V	+32767 (0x7FFF)	20 mA	+32767 (0x7FFF)	20 mA	+32767 (0x7FFF)
Lower minimum limit value	-10 V	-32767 (0x8001)	0 mA	0 ¹⁾	4 mA	0 ²⁾

1) The analog value is limited down to 0.

2) The analog value is limited down to 0 at currents <4 mA. The status bit for the lower limit is set.

Other limit values can be defined if necessary. Limit values are valid for all channels and activated automatically by writing to the limit value registers. From this point on, the analog values will be monitored and limited according to the new limits. The results of monitoring are displayed in the status register.

Examples of limit value settings

Application case	Limit value settings
Current signal: 4 to 20 mA	A negative limit value must be configured in order to measure values <4 mA with a current signal of 4 to 20 mA: 0 mA is equal to a value of -8192 (0xE000).
Mixed voltage and current signal	The configured limit values are valid for all channels. Mixed operation (voltage and current signal) therefore requires a compromise. The following configuration has proven effective: Upper limit = +32767, lower limit = -32767 This makes it possible to also measure negative voltage values. A lower limit value of 0 would limit the voltage value to 0.
Current signal on all channels	All channels are configured for measuring current. The limit value setting in Automation Studio is not adjusted automatically. That means that +32767 is configured as the upper limit value and -32767 as the lower limit value. The necessary changes must be made by the user, e.g. lower limit value = 0

8.9.1 Lower limit value

Name:

ConfigOutput03

This register can be used to configure the lower limit for analog values. If the analog value goes below the limit value, it is frozen at this value and the corresponding error status bit is set.

Data type	Values	Information
INT	-32768 to 32767	Bus controller default setting: -32768

Information:

- The default value of **-32767** corresponds to the minimum default value of **-10 VDC**.
- When configured as **0 to 20 mA**, this value should be set to **0**.
- When configured as **4 to 20 mA**, this value can be set to **-8192** (corresponds to **0 mA**) in order to display values <4 mA.

Information:

Keep in mind that this setting applies to all channels!

8.9.2 Upper limit value

Name:

ConfigOutput04

This register can be used to configure the upper limit for analog values. If the analog value goes above the limit value, it is frozen at this value and the corresponding error status bit is set.

Data type	Values	Information
INT	-32767 to 32767	Bus controller default setting: 32767

Information:

The default value of 32767 corresponds to the maximum default value of 20 mA or +10 VDC.

Information:

Keep in mind that this setting applies to all channels!

8.10 Input status

Name:
StatusInput01

This register is used to monitor the module inputs. A change in the monitoring status generates an error message. The following states are monitored depending on the settings:

Value	Voltage signal ± 10 V	Current signal 0 to 20 mA	Current signal 4 to 20 mA
0	No error	No error	No error
1	Lower limit value exceeded	Default setting The input value has a lower limit of 0x0000. Underflow monitoring is therefore not necessary. After lower limit value change The input value is limited to the configured value. The status bit is set when the lower limit value is passed.	Lower limit value exceeded
2	Upper limit value exceeded	Upper limit value exceeded	Upper limit value exceeded
3	Open line	-	-

Data type	Values
USINT	See the bit structure.

Bit structure:

Bit	Description	Value	Information
0 - 1	Channel 1	00	No error
		01	Lower limit value exceeded
		10	Upper limit value exceeded
		11	Open line
2 - 3	Channel 2	00	No error
		01	Lower limit value exceeded
		10	Upper limit value exceeded
		11	Open line
4 - 7	Reserved	0	

Limiting the analog value

In addition to the status information, the analog value is set to the values listed below by default when an error occurs. The analog value is limited to the new values if the limit values were changed.

Error status	Digital value for error (default values)
Open line	+32767 (0x7FFF)
Upper limit value exceeded	+32767 (0x7FFF)
Lower limit value exceeded	-32767 (0x8001)
Invalid value	-32768 (0x8000)

8.11 Minimum cycle time

The minimum cycle time specifies the time up to which the bus cycle can be reduced without communication errors occurring. It is important to note that very fast cycles reduce the idle time available for handling monitoring, diagnostics and acyclic commands.

Minimum cycle time	
Inputs without filtering	100 μ s
Inputs with filtering	500 μ s

8.12 Minimum I/O update time

The minimum I/O update time specifies how far the bus cycle can be reduced so that an I/O update is performed in each cycle.

Minimum I/O update time	
Inputs without filtering	300 μ s for all inputs
Inputs with filtering	1 ms